

21. Fault Diagnosis



Before carrying out checks marked #, remove power cord from wall plug.
Wiring diagram is on page 35.

Appliance will to operate (even remote control fails to operate)	
1) Is the fuse blown?	
<p>Fuses are located in plastic holders in the main harness, on the lower right hand side of the appliance</p>	<p>Check fuse</p> <ol style="list-style-type: none"> a. Remove 240V plug from socket. b. # Measure resistance to check the electric fuse (3A). <p><i>Normal:</i> less than 1Ω If normal, proceed to check item 2) below. <i>Faulty:</i> Replace fuse (5A) If it blows again, investigate cause of short circuit.</p>
2) Is the main transformer normal?	
	<p>Check the transformer.</p> <ol style="list-style-type: none"> a. Measure the voltage in between the red wires of the relay connector (A₁). <i>Normal:</i> AC90 ~ 110 V / 15 ~ 21Ω If normal, check 2 below. <i>Faulty:</i> Check for AC 90 ~ 110 V on the PCB terminal J black ~ black b. Check voltages below at upper PCB connector A. <i>Normal:</i> orange -orange AC 13 ~ 30V / 1.4 ~ 1.8Ω brown - grey AC 30 ~ 50V / 6 ~ 10Ω yellow - grey AC 180 ~ 220V / 0.4 ~ 0.6Ω If normal, check 3 at top of next page. <i>Faulty:</i> Replace the transformer.

Refer to diagram on bottom of previous page.

- c. Check the voltage at centre PCB connector F, green ~ green.

Normal: AC 16 ~ 20V

If normal, check item 3) below.

Faulty: Replace the transformer.

Note: Transformer voltage above applies to the appliance in a standby, non-functioning state.

- 3) Is the remote control normal?

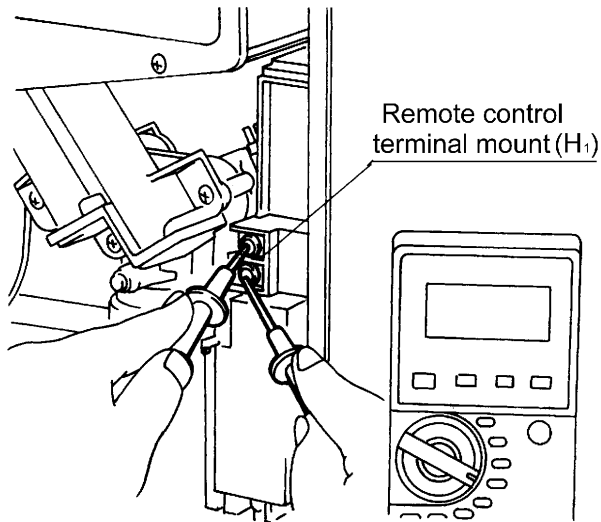

Check voltage between the two remote control cable conductors.

- a. Check the voltage between terminals on the remote control terminal mount (H₁).

Normal: DC 10 ~ 13V

If normal, check for open circuit or shorts before replacing the remote control.

Faulty: Replace PCB.

No combustion (despite remote control indication)

- 1) Is the water flow sensor normal?

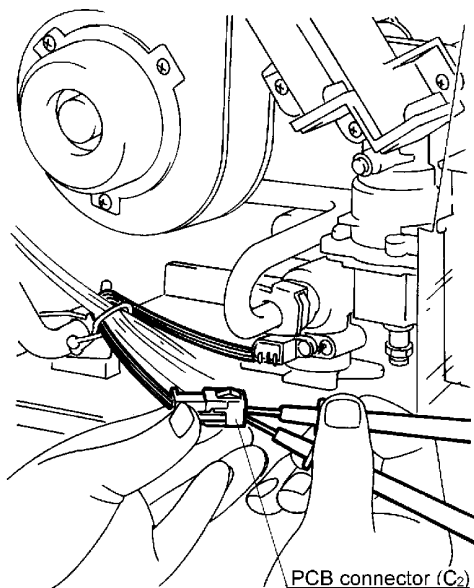

- a. Measure the voltage between red and black of the relay connector (a₂).

Normal: DC 11 ~ 13V

If normal, go to (b).

Faulty: Replace water flow control.

- b. Measure the voltage between yellow and black of the relay connector (a₂)

Normal: DC 2 ~ 10V

If normal, go to 2).

Faulty: Replace the water flow sensor.

2) Is the flame rod normal? Error “72” is displayed

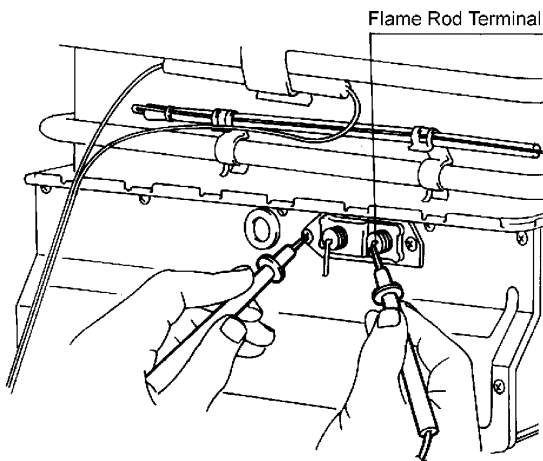

Checking the flame rod.

- a. # Detach the flame rod terminal A_2 , and re-attempt operation.
(“72” is displayed)
Proceed to check item 3) below.
(“72” is not displayed)
Inspect for electrical current leak from the flame rod.

Measure resistance between flame rod terminal A_2 and the appliance earth.

Normal: $1\text{ M}\Omega$ or more

If normal, replace the PCB unit.

Faulty: Replace the flame rod.

3) Is the water temperature thermistor normal?

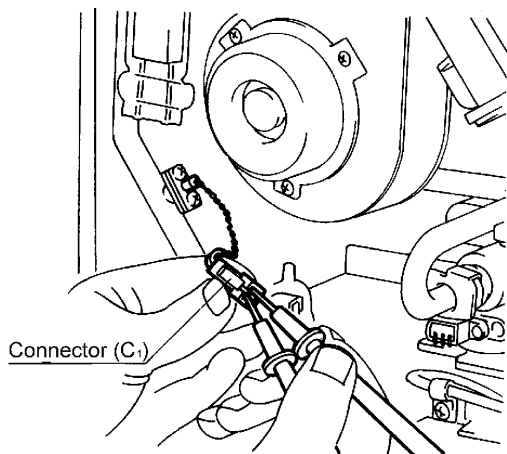

If error “32” is displayed, check the water temperature thermistor.

- a. # Disconnect connector C_1 , and measure the resistance of white and white.

Resistance $> 1\text{ M}\Omega$ = open circuit.

Resistance $<$ below 1Ω = short circuit.

Normal: proceed to check item 4.) on next page.

Faulty: replace the water temperature thermistor.

4) Is the combustion fan normal?

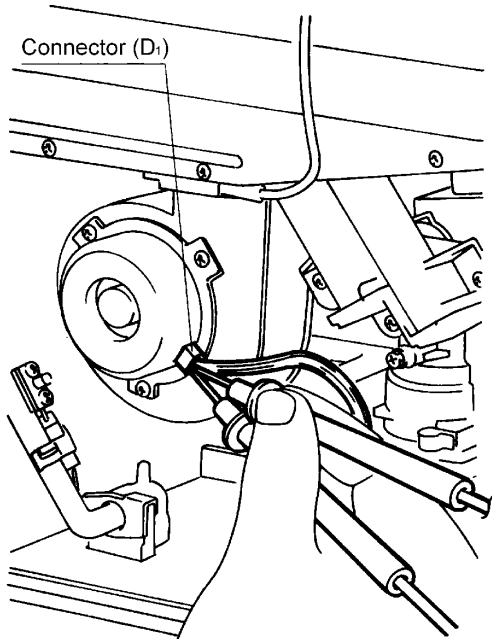

Motor check

If error "61" is displayed, check combustion fan.

- a. Measure the voltage at the connector (D₁)
black ~ red

Normal: DC 6~40V (fan on)

DC 0V (fan off)

If normal, go (b)

Faulty: Replace the PCB unit

Fan Revolution Sensor Check

- b. Measure the voltage at connector D₁,
black ~ yellow

Normal: DC11~13V

If normal, go (b) below

Faulty: Replace the PCB unit

- c. Measure the voltage at connector D₁,
black ~ white

Normal: DC2~9V

If normal, proceed to check item 5)
below

Faulty: Replace the combustion fan.

5) Is the sparker operating normally?

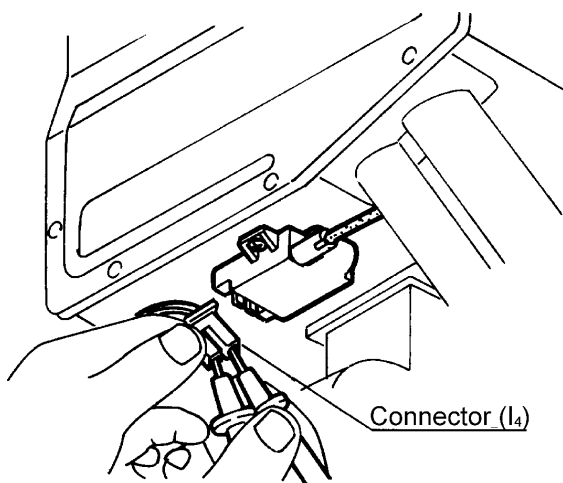

Checking the motor

- a. Measure the voltage at connector I₄.
grey ~ grey

Normal: DC 90 ~ 110 V

DC 0 V (when fan is OFF)

If normal, check (b) below.

Faulty: Replace the PCB unit

- b. # Disconnect I₄, and measure the
resistance between sparker terminals

Normal: >1MΩ

If there is no spark, adjust or replace the
electrode.

Faulty: Replace the sparker.

6) Is main gas solenoid valve (SV₁) normal?

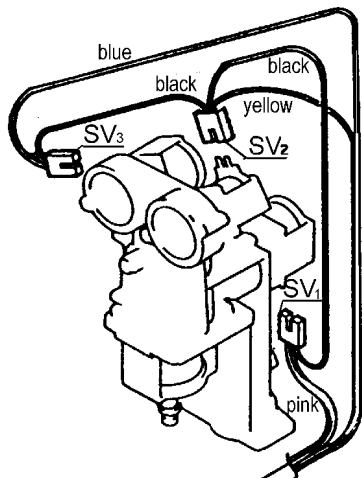

If error "11" is displayed, check the main gas solenoid valve.

- a. # Disconnect the main gas solenoid valve (SV₁), connector and measure the resistance at the solenoid terminals.
Normal: 0.9 ~ 1.3 k Ω
If normal, check (b) below.
Faulty: Replace the main gas solenoid valve.
- b. Measure voltage main gas solenoid valve (SV₂) pink ~ black connector.
Normal: DC80~100V
If normal, proceed to check item 7) below.
Faulty: Replace the PCB unit.

7) Is the change over solenoid (SV₂) operating normally?

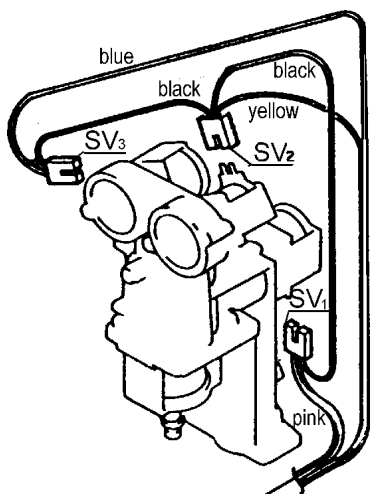

If error "11" is displayed, check the change over solenoid valve (SV₂).

- a. # Disconnect the main gas solenoid valve (SV₂) connector, and measure the resistance at the solenoid terminals.
Normal: 1.3 ~ 1.9 k Ω .
If normal, check (b) below.
Faulty: Replace the change over solenoid valve (SV₂).
- b. Measure voltage at change over solenoid valve (SV₃) blue ~ black connector.
Normal: DC 80 ~ 100V
If normal, check item 9) below.
Faulty: Replace the PCB unit

8) Is the change over solenoid valve (SV₃) normal?

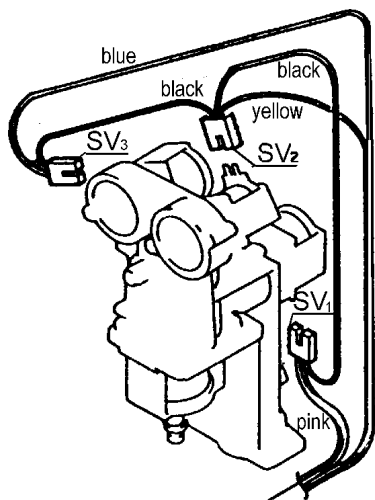

- a. # Disconnect the change over solenoid valve (SV₃) connector, and measure the resistance at the solenoid terminals.
Normal: 1.3 ~ 1.9 k Ω
If normal, check (b) below.
Faulty: Replace the change over solenoid valve (SV₃).
- b. Measure the voltage at changeover solenoid valve (SV₃) blue ~ black connector.
Normal: DC 80 ~ 100V
If normal, check item 9).
Faulty: Replace the PCB unit.

9) Are the safety devices operating normally?

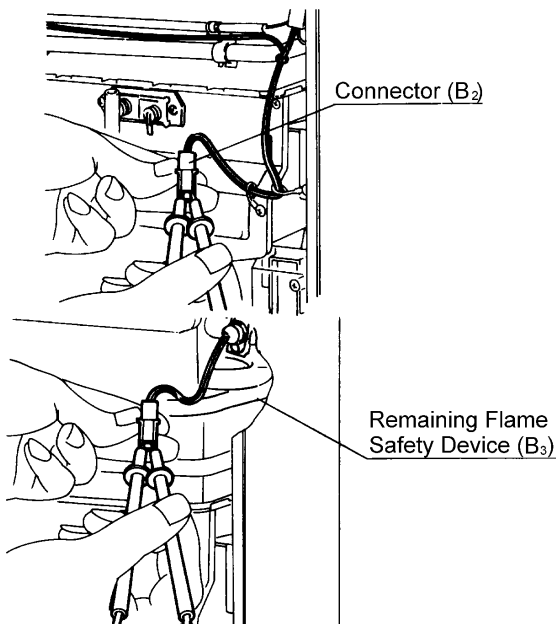

Check the thermal fuse.

- a. # Disconnect connector B₂ and measure the resistance between red ~ red.
Normal: less than 1 Ω.
If normal, replace the PCB unit.
Faulty: Check the appliance for damage.
If there is nothing abnormal, replace the thermal fuse.

Check the remaining flame safety device.

- b. Measure resistance between the two terminals B₃.
Normal: less than 1 Ω
If normal, replace the PCB unit.
Faulty: Replace the remaining flame safety device.

Combustion stops due to flame failure

1) Is the flame rod functioning normally?

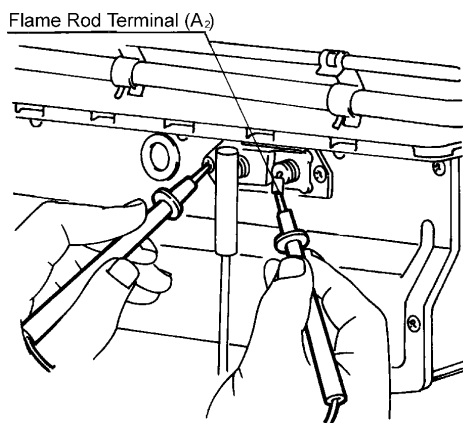

- a. Measure the voltage between the flame rod terminal (A₂) and the appliance earth.
Normal: AC 100 ~ 160V
If normal, check (b) below.
Faulty: Replace the PCB unit.
- b. Check that the flame rod attachment is not loose.
Normal: Replace the PCB unit
Faulty: Secure the flame rod brackets.

2) Is the earth lead wire normal?

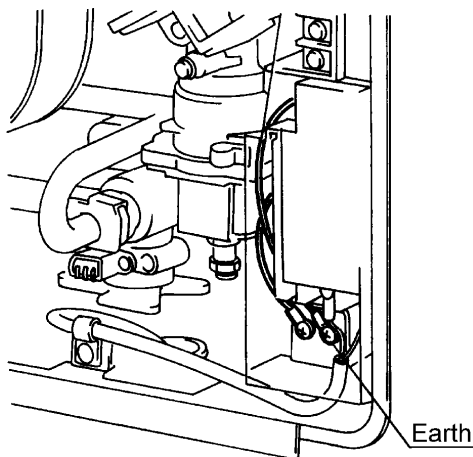

- a. Check whether the earth lead wire has come loose (disconnection from round terminal) or if any shorts have occurred.
If normal, check for any other causes for flame failure (eg. gas valve is open, blocked filter, etc)

Faulty: Secure the earth.

Unable to adjust hot water temperature

1) Is the water temperature thermistor normal?

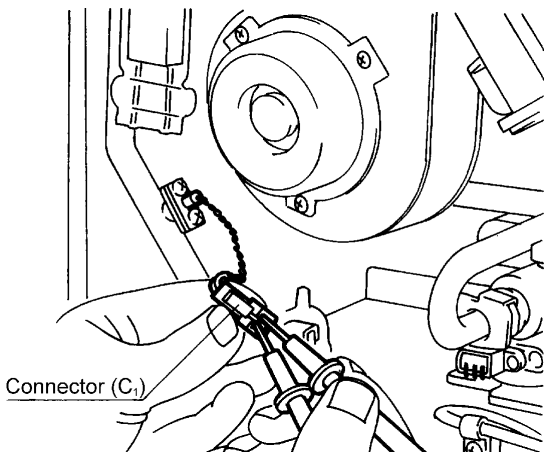

- a. Disconnect the connector (C_1) and measure the resistance between white wires.

See diagnostic points, for temperature at various resistance.

Normal: Proceed to check item 2) below
Faulty: Replace water temperature thermistor.

2) Is the changeover solenoid valve (SV_3) normal?

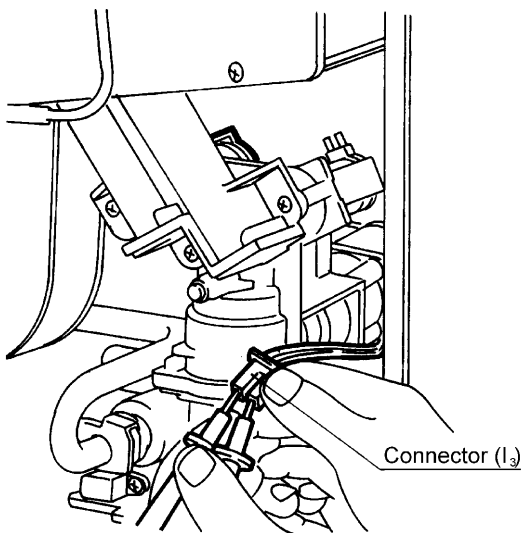

- a. # Disconnect the changeover solenoid valve (SV_3) connector, and measure the resistance between the solenoid terminals.

Normal: 1.3 ~ 1.9 k Ω .

If normal, go to (b).

Faulty: Replace the changeover solenoid valve (SV_3).

- b. Measure the voltage at the changeover solenoid (SV_3) blue ~ black connector.

Normal: DC 80 ~ 100V

If normal, go to item 3) on the next page.

Faulty: Replace the PCB unit.

3) Is the modulating valve operating normal?

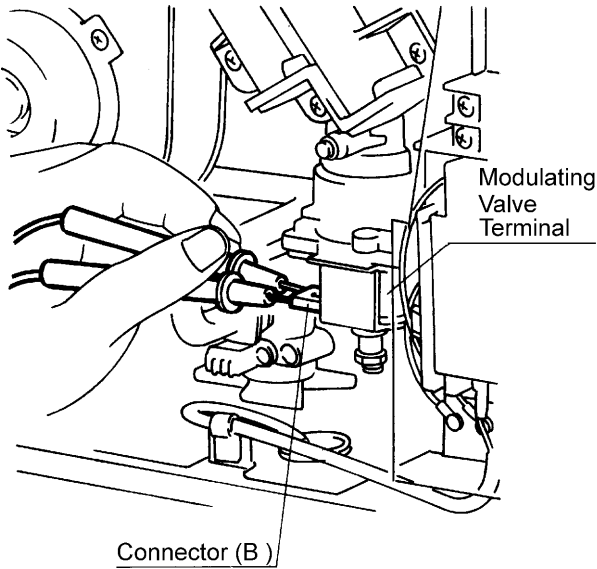

- a. # Disconnect the modulating valve festoon terminals and measure the resistance at the terminals.
Normal: 60 ~ 100Ω
If normal, go to (b).
Faulty: Replace the modulating valve.
- b. Re-connect terminal and measure the pink ~ pink voltage at the modulating valve festoon terminal.
Normal: DC 0.5 ~ 25 V
If normal, go to (c) below.
Faulty: Replace PCB unit.
- c. Investigate the change in gas secondary pressure when the remote control preset temperature is altered from 37 to 75C.
Normal: If the secondary pressure changes, proceed to check item 4) below.
Faulty: Replace the modulating valve.

4) Is the water flow servo normal? (2008/2408)

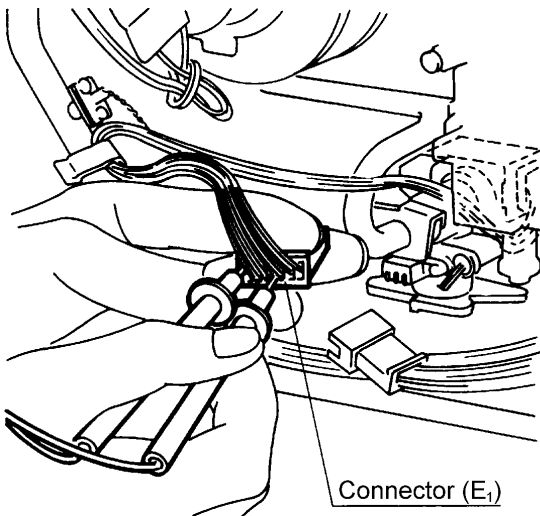

- a. # Disconnect connector and measure the red ~ blue resistance on the water flow servo side.
Normal: 10 ~ 30Ω
If normal, go to b.
Faulty: Replace the water flow servo with water flow sensor.
- b. Disconnect connector, and measure the voltage between orange (+) and grey(-) on the water flow control side.
Normal: DC 11 ~ 13 V
If normal, go to (c).
Faulty: Replace the PCB unit.
- c. With connector (E₁) connected (do not turn water ON... wait for the water flow servo to return to fully open), measure the voltage between brown and grey.
Normal: DC 4 ~ 6V
Faulty: Change water flow servo with sensor.
- d. Leaving the relay connector (E₁) connected (do not turn water ON... wait for the water flow servo to return to fully open), measure the voltage between yellow and grey.
Normal: Less than DC 0.5 V
Faulty: Change water flow servo with sensor.

Anti frost heater does not operate

1) Are the ceramic anti-frost heaters OK?

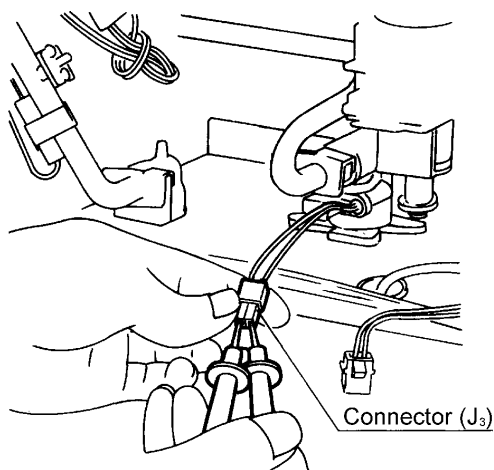

- a. # Disconnect connector (J₃) and measure the blue and blue resistance on the water control heater side.

Normal: 950~1050Ω (2424, 2408, 2008)
590 ~ 660Ω (2007)

If normal, go to (b).

Faulty: Replace the water control heater (2424, 2408, 2008).

Replace the anti-frost heater D assy (2007).

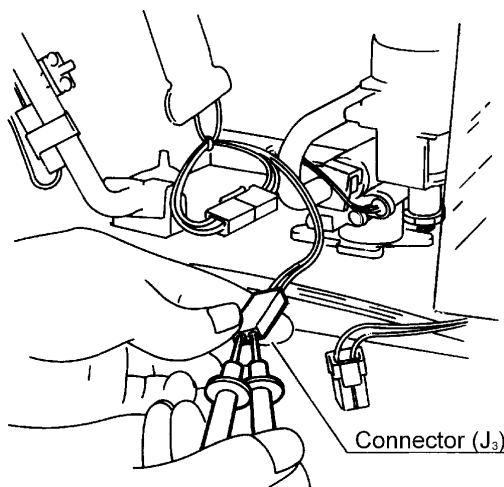

- b. # Disconnect connector (J₃) and measure the resistance between blue and blue on the heater exchanger's heater side.

Normal: 135 ~ 175Ω

If normal, go to item 2) below.

Faulty: Replace anti-frost heater (assy)

2) Is the frost sensing switch normal?

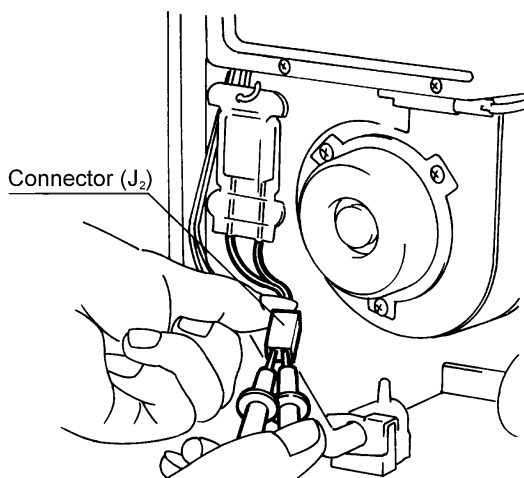

- a. # Detach connector (J₂) and measure the resistance between blue and blue.

*Measure at room temperature of 4± 3° C.**

Normal: Less than 1Ω

if normal, check the wiring (AC100V circuit)

Faulty: Replace the frost sensing switch.

* *Where the low room temperature cannot be achieved, please cool with iced water or cold water below 4° C.*