



# Rinnai

## GAS RICE COOKER

### INSTALLATION AND OPERATING INSTRUCTIONS

MODEL RER-55AS

#### WARNING

IMPROPER INSTALLATION, ADJUSTMENT, ALTERATION, SERVICE OR MAINTENANCE CAN CAUSE PROPERTY DAMAGE, INJURY OR DEATH. READ THE INSTALLATION, OPERATING AND MAINTENANCE INSTRUCTIONS THOROUGHLY BEFORE INSTALLING OR SERVICING THIS EQUIPMENT.

#### Important Safety Information

Gas Safety (Installation and Use) Regulations 1994 on the "Rules in Force"  
In your own interest and that of safety, it is law that all gas appliances shall be installed by competent persons in accordance with the above regulations. Failure to install appliances correctly could lead to prosecution. Other persons should NOT attempt to install this equipment.

INSTALLER MUST LEAVE THIS MANUAL WITH UNIT AFTER INSTALLATION, CONSUMER TO RETAIN FOR FUTURE REFERENCE.

# TABLE OF CONTENTS

## GENERAL INFORMATIONS

Page

1. NAME OF PARTS ..... 1
2. SPECIFICATIONS ..... 1

## INSTALLATION INSTRUCTIONS

1. NOTICE BEFORE INSTALLATION ..... 2
2. LOCATION AND CLEARANCES ..... 2

## OPERATING INSTRUCTIONS

1. OPERATING INSTRUCTIONS ..... 3
2. HOW TO COOK RICE ..... 4
3. VISUAL BURNER CHECK ..... 5

## MAINTENANCE

1. CLEANING ..... 6
2. TROUBLE SHOOTING ..... 6

- Appendix SCHEMATIC DISASSEMBLY ..... 8

# GENERAL INFORMATIONS

## 1. NAME OF PARTS

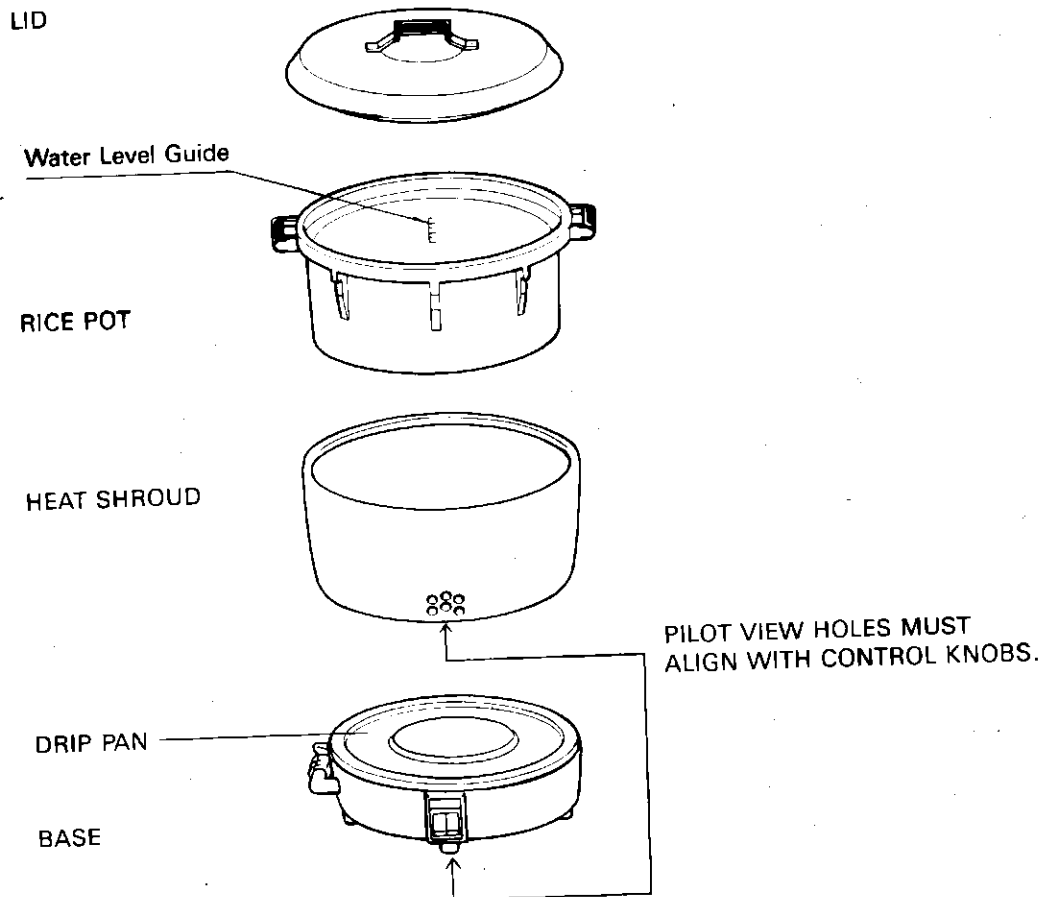

## 2. SPECIFICATIONS

TYPE	Gas Rice Cooker	
MODEL	RER-55AS	
DIMENSIONS	Height	457 mm
	Width	595 mm
	Depth	484 mm
WEIGHT (Net.)	16 kg	
RICE CAPACITY	10 Litres	
GAS CONNECTION	1/2" BSP Female	
SAFETY DEVICE	Flame Failure Safety Device	
INPUT RATING	35,000 BTU/h (NAT. GAS), 34,000 BTU/h (LP. GAS)	
CERTIFICATION	BELGIAN GAS ASSOCIATION	

# GENERAL INFORMATIONS

## 1. NAME OF PARTS

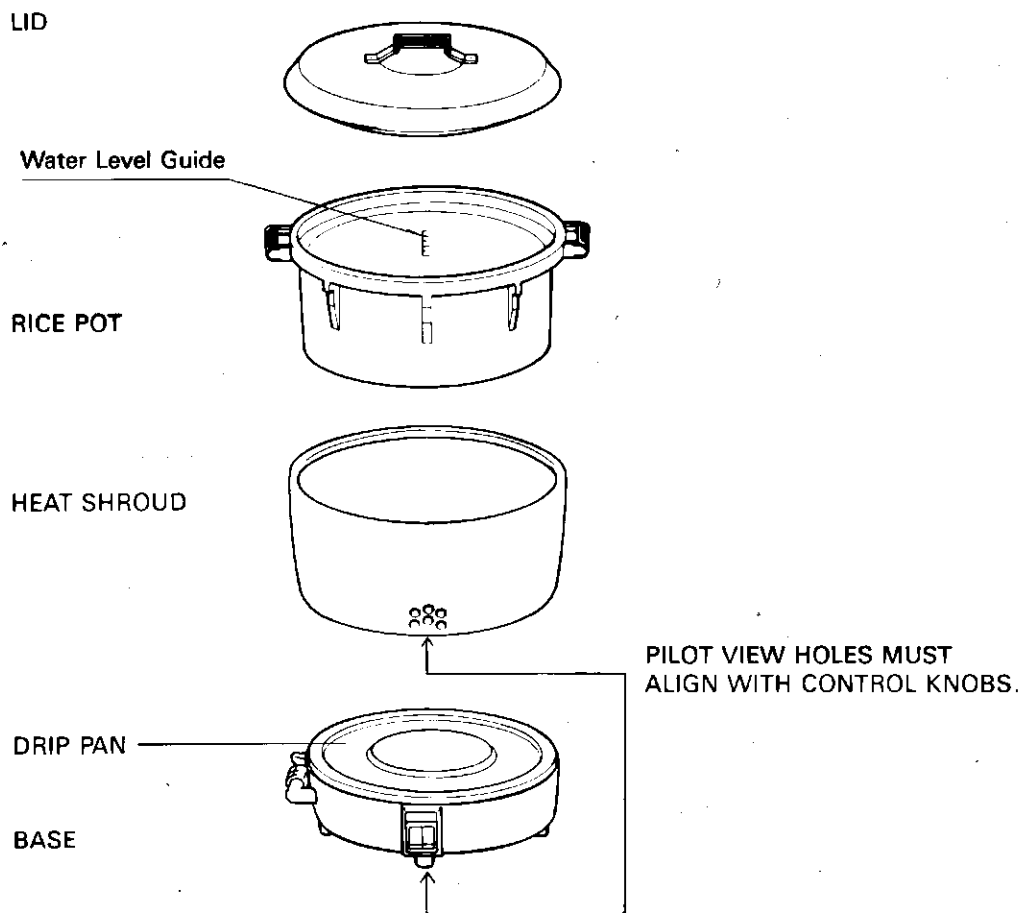

## 2. SPECIFICATIONS

TYPE	Gas Rice Cooker	
MODEL	RER-55AS	
DIMENSIONS	Height	457 mm
	Width	595 mm
	Depth	484 mm
WEIGHT (Net.)	16 kg	
RICE CAPACITY	10 Litres	
GAS CONNECTION	1/2" BSP Female	
SAFETY DEVICE	Flame Failure Safety Device	
INPUT RATING	35,000 BTU/h (NAT. GAS), 34,000 BTU/h (LP. GAS)	
CERTIFICATION	BELGIAN GAS ASSOCIATION	

# INSTALLATION INSTRUCTIONS

## 1. NOTICE

1. This rice cooker is designed either for use with Natural Gas or L.P.Gas. Make sure that type of gas to be supplied to this cooker matches to that shown in the rating plate in the unit. Install to current standards.
2. **NOTICE TO GAS INSTALLERS:** The following must be carried out to check the proper operation of the Safety Valve:
  1. Remove Pot, Heat Shroud and Drip Tray.
  2. Push Ignition Knob down until it clicks and hold knob down for approximately 2-3 seconds.
  3. Release Ignition Knob-pilot should be lit. If pilot is not lit, repeat step 2.
  4. The Keep Warm Knob will remain down.
  5. Pull Keep Warm Knob up and listen carefully for a faint metallic click sound. This click sound is the Safety Valve dropping out and signifies proper operation of Safety Valve.

**NOTE:** The Pilot Valve does not have a means to stop the flow of gas other than the manual valve outside the unit or the Keep Warm Knob.

## 2. LOCATION AND CLEARANCES

### LOCATION

1. Keep the appliance area free and clear from combustible materials, gasoline and other flammable vapors and liquids.
2. Locate this rice cooker in a well ventilated place. Do not block or cover the opening between the shroud and pot. **DO NOT OBSTRUCT FLOW OF COMBUSTION AND VENTILATION AIR.**

### CLEARANCES

Minimum clearances from combustible materials are as follows:  
15 cm from side and 15 cm from back.

Minimum clearances from NON-combustible materials are as follows:  
0 from side and 0 from back.

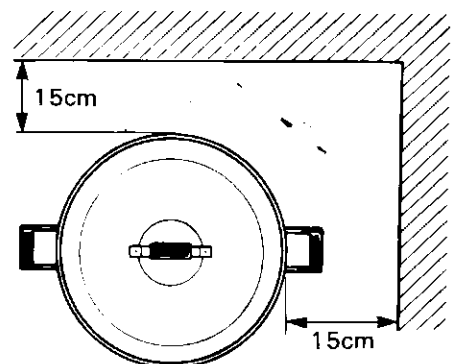

# OPERATING INSTRUCTIONS

## 1. OPERATING INSTRUCTIONS

- 1) Be sure that manual valve is open and (6) six pilot view holes are directly above controls. See pages 1 and 5.
- 2) Push **1.IGNITION** knob down until it clicks and hold down for approximately 10 seconds.
- 3) Release **1.IGNITION** knob, check that the PILOT is lit by looking through the six pilot view holes. (**1.IGNITION** knob will return and **KEEP WARM** knob stays down.)
- 4) If the PILOT has failed to ignite, then repeat 2.
- 5) To light main burner push **2.COOKING** knob down. Check main burner ignition by viewing through 6 view holes.

**NOTE:** \*The Heat Shroud if not correctly installed will prevent main burner from igniting even though the pilot is burning.

\*Do not pull **KEEP WARM** knob up while cooking. Unit will shut off.

\*Should the main burner not be ignited, or be extinguished halfway, pull **2.COOKING** knob up until it clicks.

\*Do not push **2.COOKING** knob first, the lever will not stay down unless the pilot is lit.

\*After cooking, **2.COOKING** knob will automatically lift up.

## 2. TO SHUT OFF

When removing the pot after cooking, make sure to push **KEEP WARM** knob up until it clicks. It is then in "OFF" position.

**WARNING:** \*When igniting make sure not to put your face near the viewing holes.

\*If it is hard to see the PILOT flame, relocate the position of the shroud so view holes are directly over controls. See pages 1 and 5.

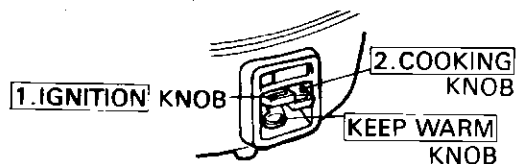
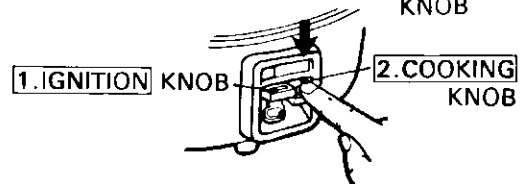
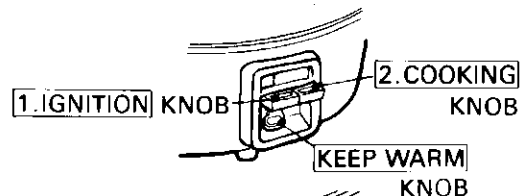
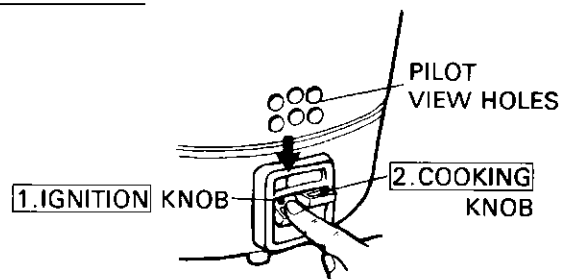

**NOTE) DO NOT PULL KEEP WARM KNOB UP WHILE COOKING.**

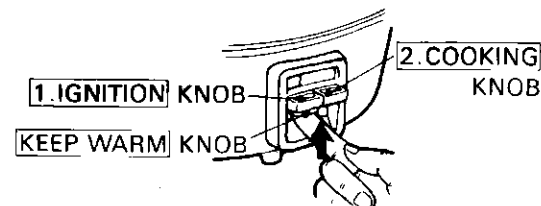
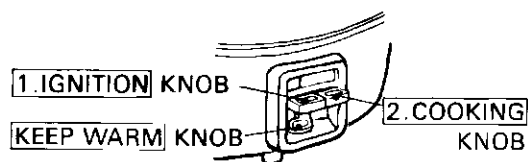
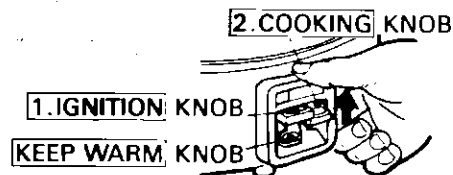

## 2. HOW TO COOK RICE

1. Measure rice.
2. Wash measured rice with fresh water until water is relatively clear to suite individual cooking taste.
3. Put the washed rice in the Rice Pot. Add water according to Water Level Guide inside the Pot.  
(For example, to cook 9 litres of rice, put the washed rice into Rice Pot and then add water up to the indication "9" of Water Level Guide.

**NOTE:** A. The amount of water is important for rice cooking. It will vary with dryness, age and kinds of grain. To suit your needs and tastes, you may need to adjust the water level.

B. Do not put water over the top line of Water Level Guide.

4. Soak rice in water about 30 minutes before you start cooking.

Water Level Guide

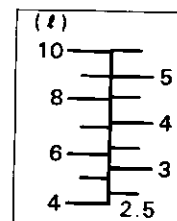

SCALE

5. Align pilot holes in Heat Shroud directly over on/off switch. Be sure that the Shroud is sitting firmly in Drip Pan. Install the Pot into the Shroud. Make sure that the Pot is level and sitting firmly in the Shroud.

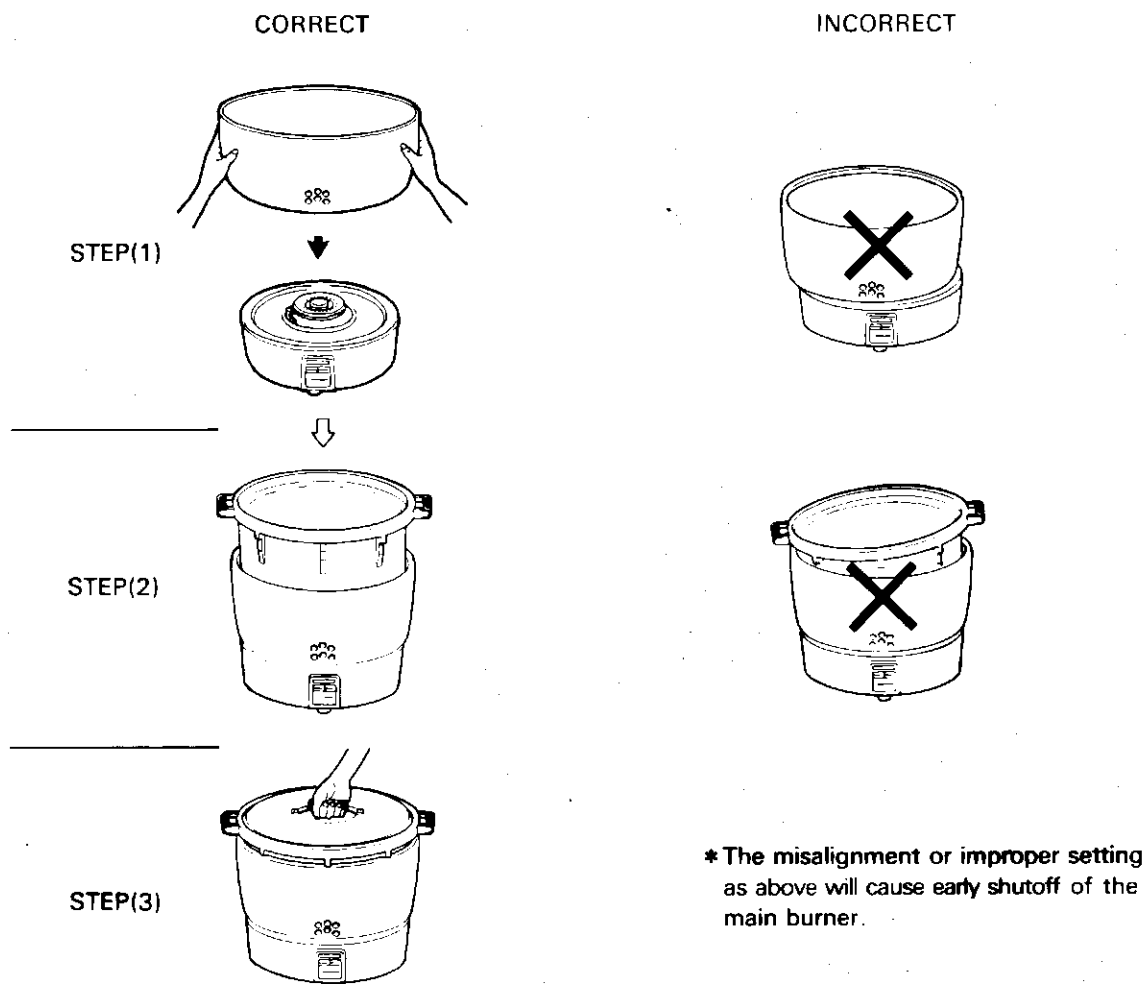

6. Close lid and light the burner. (To light the burner, refer to the operation instruction on page 3.) Do not open lid while cooking.
7. When cooking is completed, the #2(TWO) button will pop up and the main burner will automatically shut off.  
Do not open the lid immediately. Leave rice cooker with pilot on at least 15 minutes after main burner shuts off to complete the cooking process.
8. The pilot keeps cooked rice warm. After one hour, cooked rice will begin to lose flavor.
9. Shut pilot off by pushing up on keep warm knob until click is heard.

### 3. VISUAL BURNER CHECK

Make sure view holes are directly over controls.

Make a visual check of main and pilot burner flames. Flame should be light blue in color and should have no yellow tips or lifting from the burner.

Do not hold face near (6) six view holes while igniting.

# MAINTENANCE

## 1. CLEANING

Allow unit to cool for one hour.

### IMPORTANT :

1. Clean heat sensitive portions at the center of the base and at the bottom center of Rice Pot daily. Wipe water, oil and dirt with a cloth.

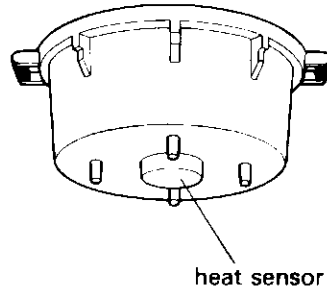
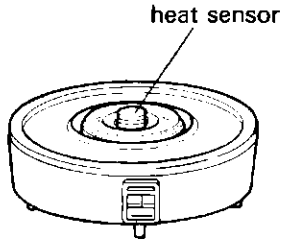

2. The rice pot, shroud, and lid can be washed with soap and water. Use normal dishwashing detergent. Wipe thoroughly with a dry cloth after washing. Do not wash the Burner Assembly with water.
3. Wipe away water, oil and dirt from drip pan with a wet cloth.
4. The burner ports should be cleaned out if blockage occurs by service technician or gas company.

## 2. TROUBLE SHOOTING

TROUBLE	CAUSE	PROCEDURE
1. Main burner shut off before rice completely cooked	Too little water for rice volume.	Cook with proper amount of water. See directions.
	Spillage on thermal sensing unit.	Clean thermal sensing unit. See above for cleaning.
	Drip Pan, Rice Pot and/or Heat Shroud are not correctly positioned.	Place cooker parts in correct position. See directions.
	Thermostat is malfunctioning or dirty.	Replace thermal sensing unit assembly. Contact your dealer for parts or cleaning.

TROUBLE	CAUSE	PROCEDURE
2. Pilot and Main Burner shut off while cooking.	Spillage on Pilot Unit	Clean Pilot Burner or replace.
	Pilot Injector is clogged.	Clean Pilot Injector or replace.
	Gas supply pressure is too low.	Check gas line for proper size. All valves must be fully opened.
	Thermocouple is covered with spillage or damaged.	Clean thermocouple or replace.
3. Main Burner does not shut off automatically.	Thermostat is malfunctioning or dirty.	Clean heat sensing parts. Replace Thermal Sensing Unit Assembly. Contact you dealer for parts.
4. Short flame main burner.	Gas supply pressure is too low.	Check gas line for proper size. All valves must be fully opened. Contact your gas company.
	Blockage of main orifice.	Clean main orifice or replace.
5. Yellow flame main burner. Soot on the bottom of Rice Pot.	Incorrect type of gas.	Check rating plate and make sure of gas type.
	Spillage on main burner. Main burner is covered with spillage or insects inside of main burner.	Clean main burner or replace it. Check inside of main burner.
6. Flame is lifting.	Spillage on main burner. Blockage of main burner parts and holes.	Clean main burner parts or replace main burner.
7. Boiling over.	Too much water.	Cook with proper amount of water. See directions.
8. Inside of Rice Pot turns dark gray.	Rice Pot is not used for a long time without wiping after washing.	Wipe pot with dry cloth thoroughly after washing.
	Rice Pot is sterilized by steaming. Surface of aluminum may turn dark gray.	This discoloration of aluminum is not harmful to your health.

# SCHEMATIC DISASSEMBLY

MODEL RER-55AS

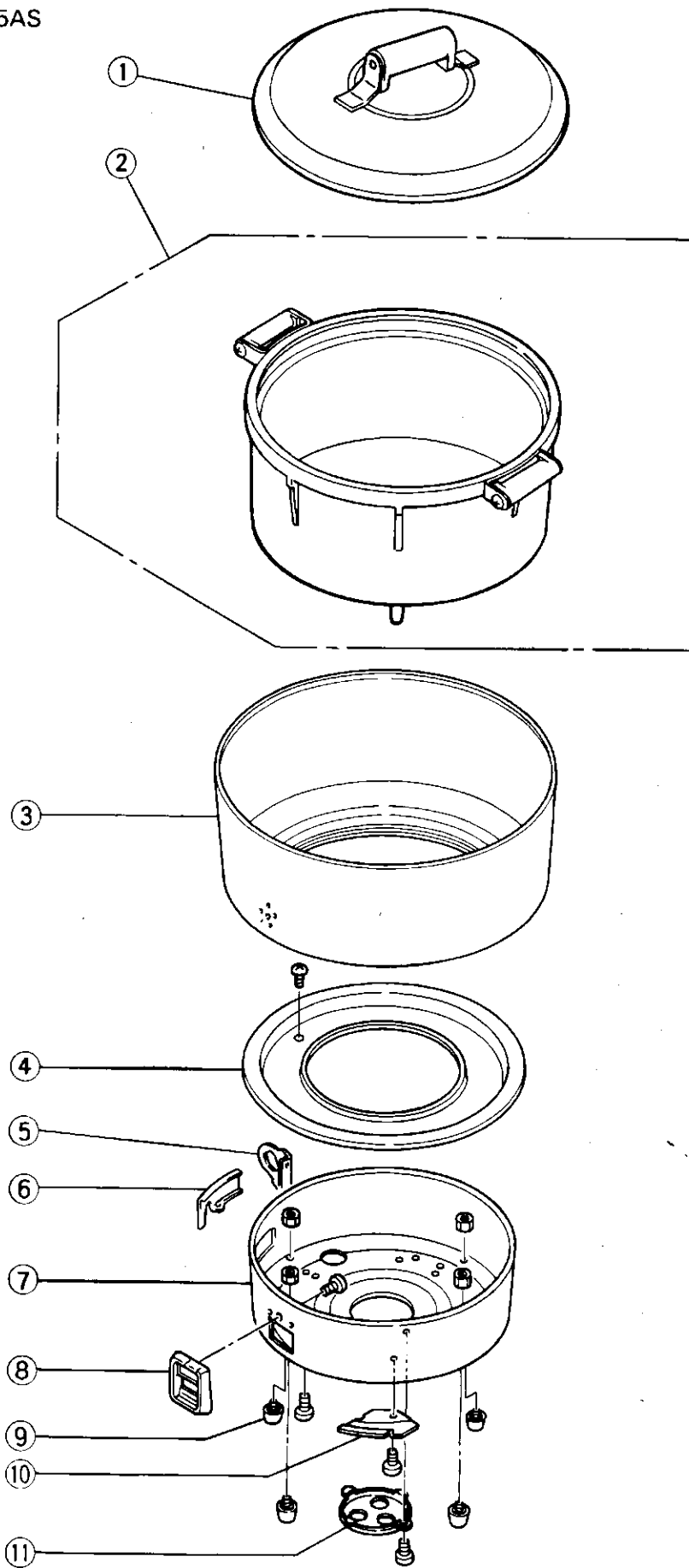

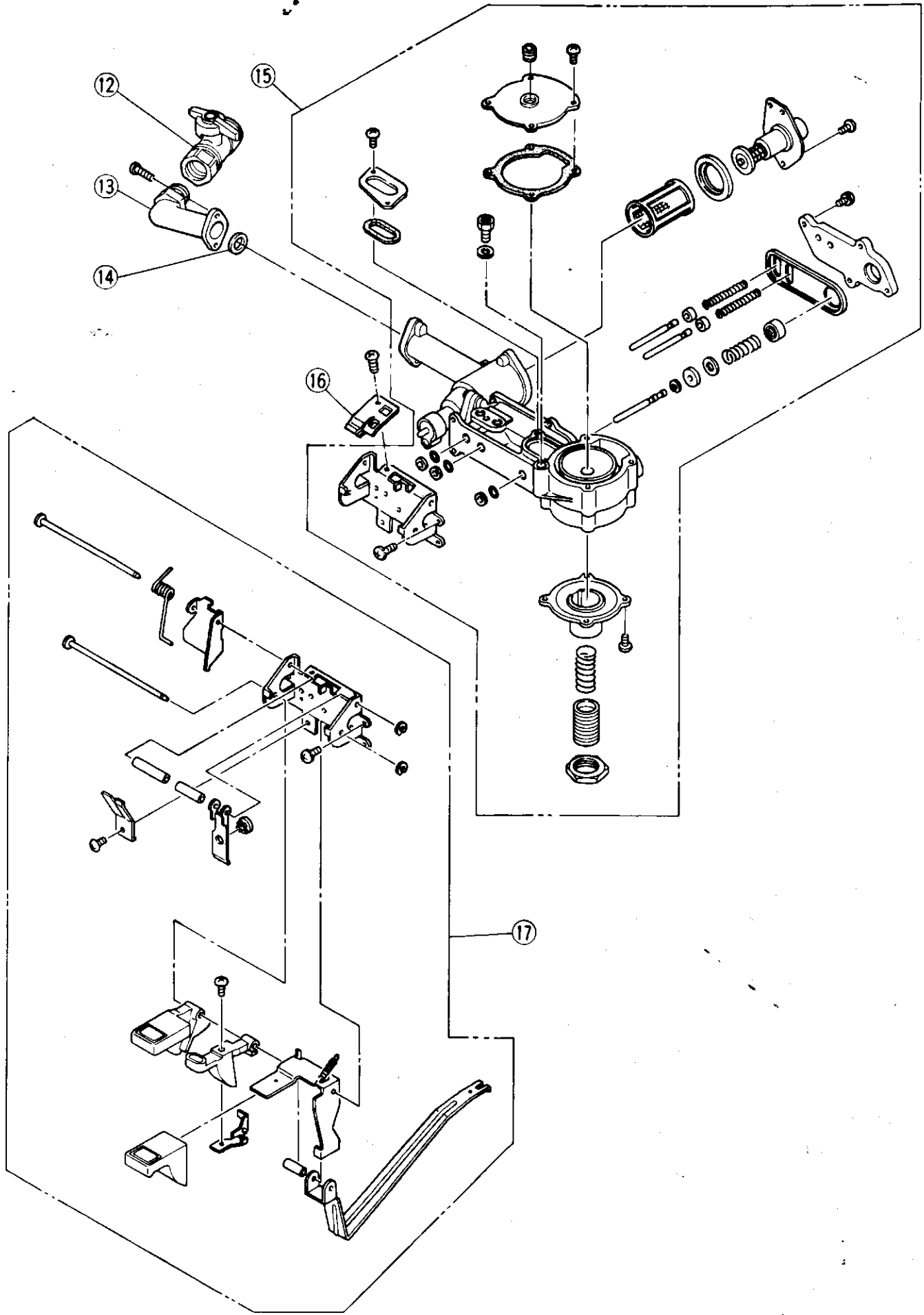

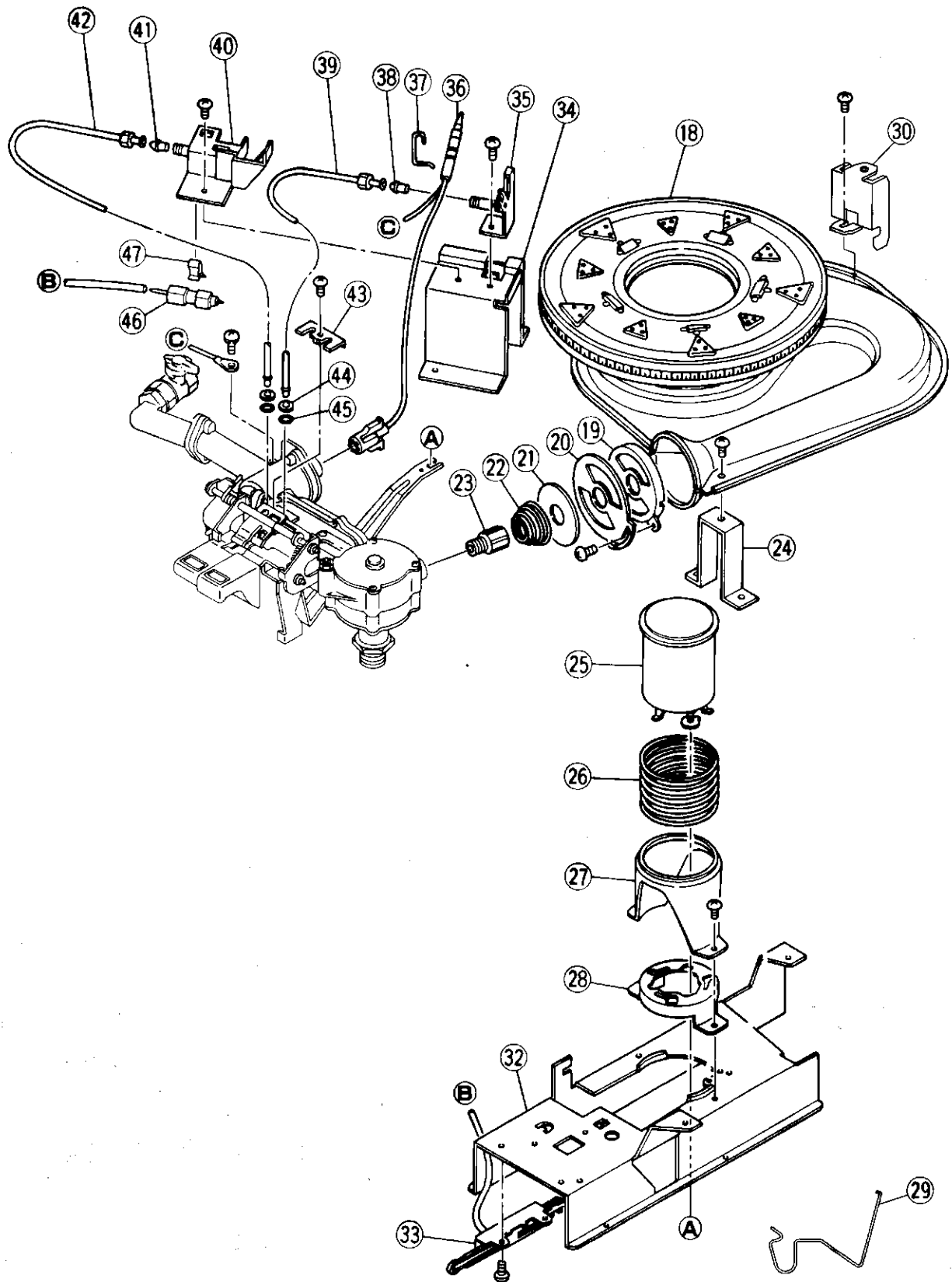

## PARTS LIST GAS RICE COOKER

NO.	PART NAME	DRAWING NO.
1	Lid Ass'y	RR84-32034
2	Rice Pot Ass'y	RR77-1733
3	Heat Shroud	RR77-20413
4	Drip Pan	36550
5	Cock Mount Plate	BRR37-113
6	Cnnecting Inlet Cover	BRR37-345
7	Bottom Casing	RR82-2655
8	Control Panel	BRR37-105
9	Rubber Leg Ass'y	49231
10	Pressure Adjust. Hole Cover	BRR37-332
11	Under Cover	RR77-4590
12	Manual Valve	BRR37-244
13	Cock Joint	BRR37-401
14	Packing	C36E1-6
15	Combination Control Ass'y	DRR37-213
16	Lock Plate	ARR37-600
17	Operating Unit	BRR37-243
18	Burner	CRR37-338
19	Air Shutter Plate	BRR37-315
20	Air Shutter	BRR37-313
21	Supplementary Damper	BRR37-340
22	Damper Push Spring	RR77-4641
23	Main Injector (for Propane Gas) $\varnothing$ 1.67 Main Injector (for Natural Gas) $\varnothing$ 2.5	RMC-7523-167 RMC-7523
24	Burner Fitting Board	ARR37-104
25	Thermal Sensing Unit Ass'y	BRR37-505
26	Thermal Sensing Unit Spring	46608
27	Magnet Case Guide	RR77-3582
28	Base Magnet Case	39346A
29	Thermal Sensing Stopper Pin Spring	ARR40-306
30	Drip Pan Fixing Plate	BRR37-103
32	Burner Plate	RR77-2588
33	Piezo Ele' Ignition Device	BRR37-1
34	Pilot Fitting Board	BRR37-329
35	Constant Pilot Burner	BRR37-326-2
36	Thermocouple	RR82-41318-02
37	Thermocouple Fixing Ping	ARR32-623
38	Pilot Injector (Permanent) (for Propane Gas) $\varnothing$ 0.21 Pilot Injector (Permanent) (for Natural Gas) $\varnothing$ 0.25	ARR37-331 6541-96
39	Constant pilot Tube	BRR37-403-1
40	Pilot Holder Ass'y	CP-50746
41	Pilot Injector (Ignition) (for Propane Gas) $\varnothing$ 0.4 Pilot Injector (Ignition) (for Natural Gas) $\varnothing$ 0.65	6541-96 6541-96
42	Ignition Pilot Tube	BRR37-403-2
43	Connecting Tube Push Metal	ARR37-333
44	Washer	CP-20805
45	O-Ring	C5G1-8
46	Electrode	CP-50188
47	Plug Holder	CP-50709
48	Instructions	TRER55AS

---

**Rinnai UK Limited**

9 Christleton Court, Manor Park, Runcorn,  
Cheshire WA7 1ST, UK

Tel : 1928-531-870 Fax : 1928-531-880

---



02358965

TRER55AS-RUK

Printed in Japan 2004.9